



**TURTLE
BEACH®**

EARFORCE®
X32



User Guide

5GHz WiFi
DUAL BAND WIRELESS



What's in the Box



X32 Headset



XBOX 360
Talkback Cable

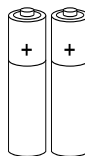

(2) AAA Batteries



X32 Wireless Digital
RF Transmitter

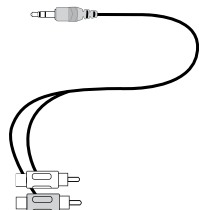

RCA Splitter Cable



Turtle Beach Sticker

Table of Contents

X32 Headset	pg 1
X32 Transmitter	
Overview	pg 2
Using the Transmitter	pg 3
Pairing the Headset and Transmitter	pg 4
Setup	pg 5
Equalizer and Sound Field Expander Presets	pg 11
Chat Boost™	pg 12
Technical Specifications	pg 13
Troubleshooting	pg 14
Important Safety Information	pg 14



watch X32 training videos at:
www.youtube.com/TurtleBeachVideos

product support and warranty information:
www.TurtleBeach.com/support

X32 Headset

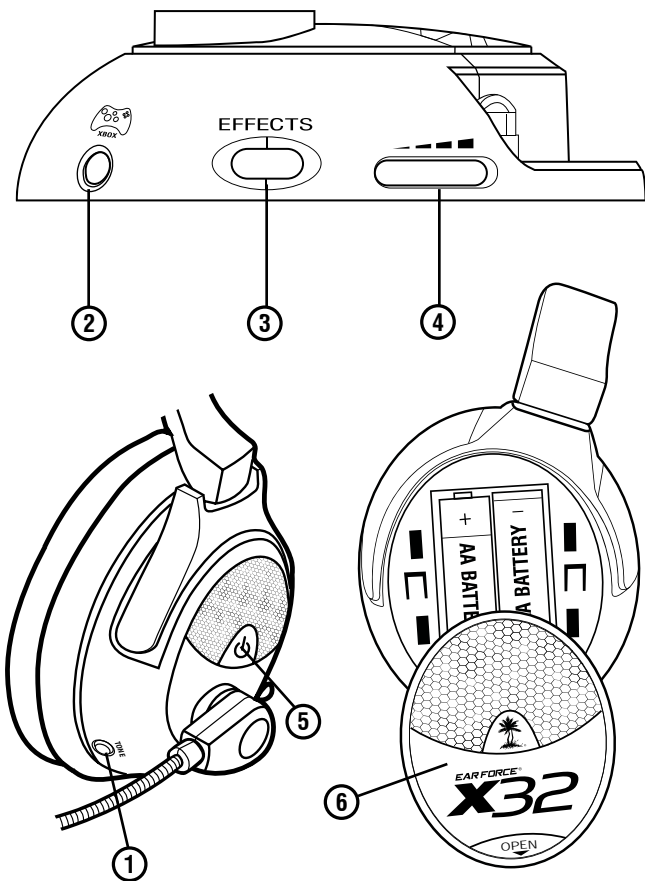

- ① **Tone Button:** Press this button to activate the different EQ presets. A beep will indicate which preset is selected. (see pg. 11)
- ② **XBOX Controller Jack:** Insert the straight connector on the talkback cable here. (see pg. 8)
- ③ **Effects Button:** Press this button to activate the different Sound Field presets. A beep will indicate which preset is selected. (see pg. 11)
- ④ **Game Volume:** Turn to adjust the game sound level. The XBOX LIVE chat volume may be independently set by the volume control on the talkback cable.
- ⑤ **Power Button:** Turn on the headset by pressing the power button for a couple of seconds, then release. You will hear 2 beeps and the power LED should start flashing. Turn off the headset by pressing the button until the LED stays on and you hear 2 beeps, then release. To enter Pairing Mode, press and hold the power button for about 6 seconds until you hear 2 fast beeps and the LED begins to flash rapidly (see pg 4). The headset will turn off after several minutes if there's no audio detected or if the transmitter is turned off.
- ⑥ **Battery Compartment Cover**
Slide down the panel on the right ear cup to access the battery compartment. The headset is powered by (2) AAA batteries (included) which should provide up to 15 hours of use. Rechargeable NiMH batteries may also be used. A tone will sound every 6 seconds when battery power is low.

NOTE: Be sure to insert the batteries as shown.

X32 Transmitter



- ① **Power/Link LED:** When the transmitter is powered on and communicating with the headset, this LED will be on solid. When the headset is turned off, the LED on the transmitter will turn off. A slowly pulsing LED indicates that the transmitter can't communicate with the headset. This could happen when the headset is out of range or not paired with the transmitter. (see pgs. 3-4)
- ② **Game Audio Input Jack**
Insert the 3.5mm end of the included RCA Splitter Cable into this jack.
- ③ **Auxiliary Input Jack:** Provides a 3.5mm input for digital music players or additional audio sources. (3.5mm cable sold separately)
- ④ **Pairing Button:** Press and hold to activate pairing mode. (See pg. 4)

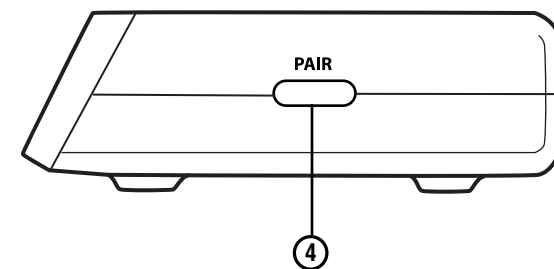
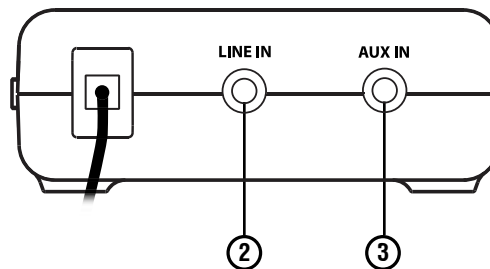

Using the Transmitter

Transmitter Range

The transmitter sends game audio from your Xbox 360 to the headset via digital radio frequency (RF) signal, so a direct line of sight is not required. When you're out of range, you may hear popping or clicking sounds if the headset loses the RF signal. For best performance, place the transmitter in an open area that is unobstructed by objects that might absorb RF signals from the internal antenna. Avoid placing it on a metal surface, such as the top of a home theater A/V receiver.

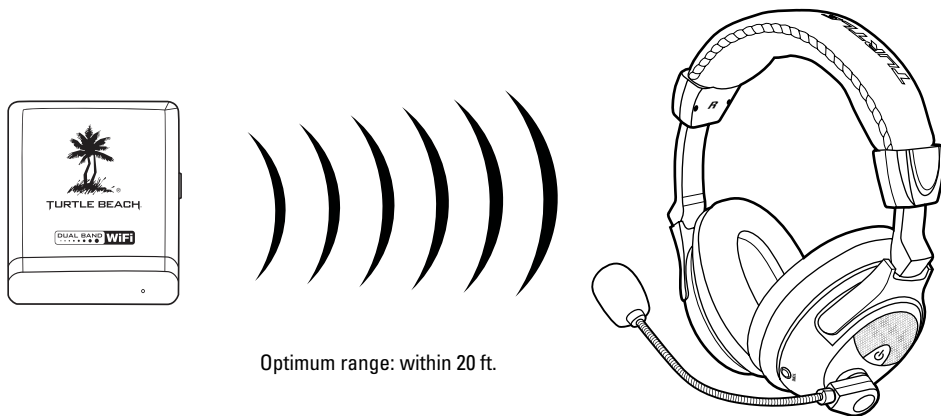

Dual-Band WiFi

The X32 uses advanced "Dual-Band WiFi" radio technology to help eliminate interference with additional wireless devices and WiFi networks. The dual-band radio uses both 5GHz and 2.4GHz signals to transmit high fidelity digital audio and help eliminate interference with other wireless devices. Unlike the RF technology used in most other wireless headsets, this dual-band WiFi radio technology coexists with wireless networks for optimum performance.



Pairing the Headset and Transmitter

The headset and transmitter in this package are "paired", which means they're synchronized to ensure they work together. When the headset and transmitter are communicating, the top LED on the front panel of the transmitter will be on solid. If this LED is instead slowly pulsing, it means the transmitter can't communicate with the headset. This could happen when the headset is out of range or not paired with the transmitter. If the LED is slowly pulsing when the headset is on and within range, then they might need to be "paired" as described below:

Step 1:

Make sure the headset is turned off.

Step 2:

Press and hold the headset power button for about 6 seconds until you hear 2 fast beeps and the LED begins to flash rapidly, then release.

Step 3:

Press and hold the **PAIR** button on the transmitter. The transmitter LED will begin to flash rapidly. When the Power/Link LED on the transmitter turns off, release the button.

After a few seconds, the Power/Link LED on the transmitter should be on solid and the headset LED should be flashing about once per second, indicating that the units are paired.

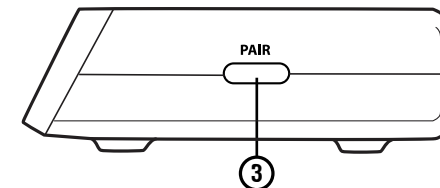
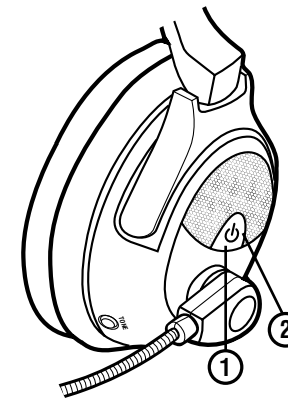

Interference from Two Headsets

Only one headset can be paired with the transmitter. If you pair two headsets with the same transmitter, they'll interfere with each other as they compete for the transmitter RF signal. This will cause one headset to shut off. So don't try to pair two headsets with the same transmitter!

XBOX 360 Setup (HDMI)

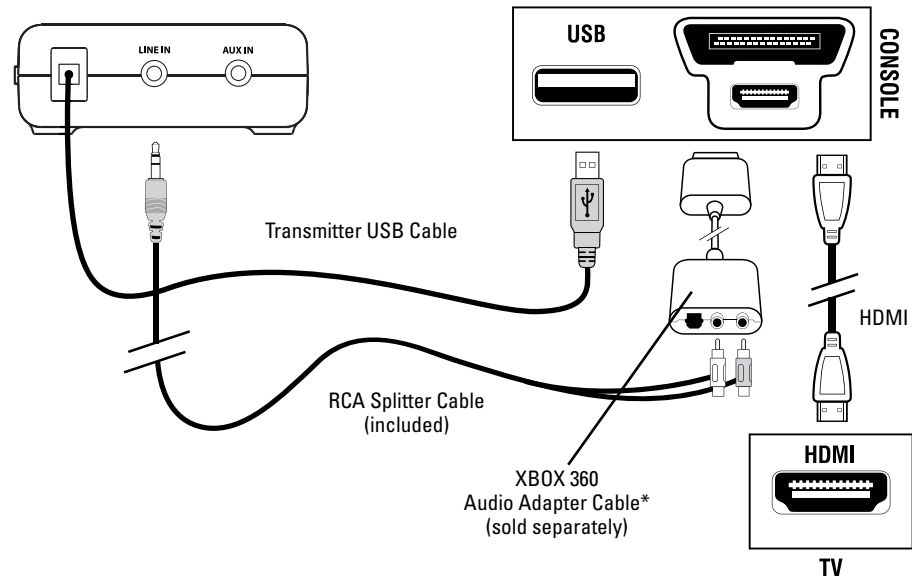

XBOX 360 Setup (HDMI)

(Alternate Setup)

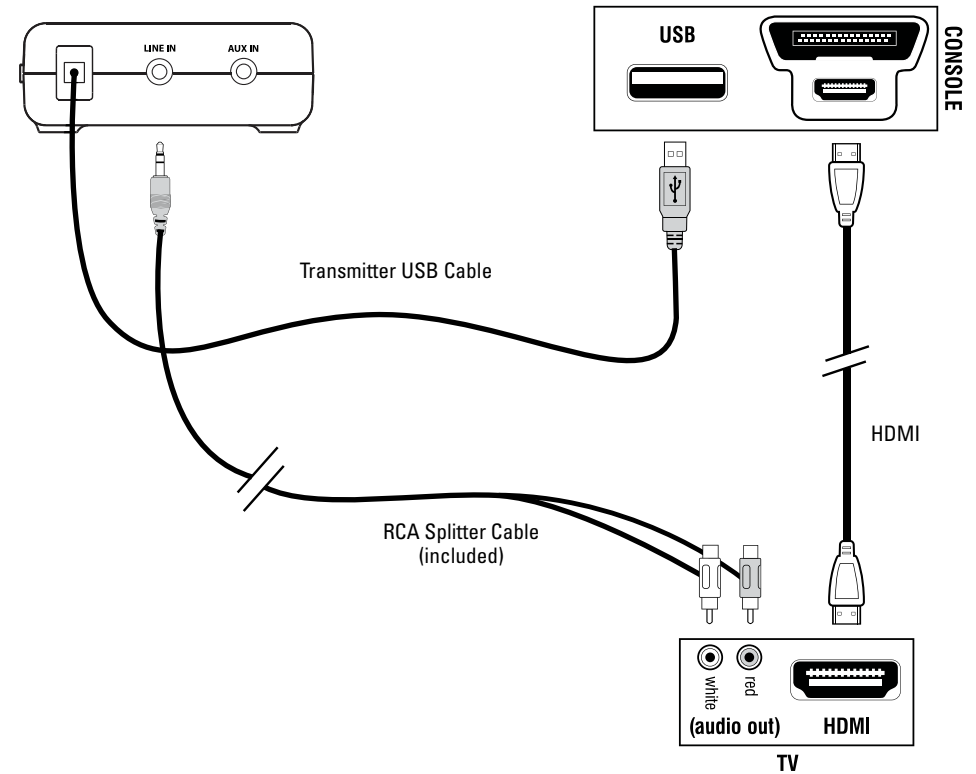

*All XBOX 360 models require an XBOX 360 Audio Adapter Cable for audio output when used with an HDMI connection (available from third party sellers).
NOTE: If your HDMI TV has red/white RCA AUDIO OUT jacks you can use it to feed the sound from your TV to your Turtle Beach headset. (AUDIO IN jacks will not send sound out to your headset, you need AUDIO OUT as shown in the alternate setup.)

XBOX 360 Setup (RCA)

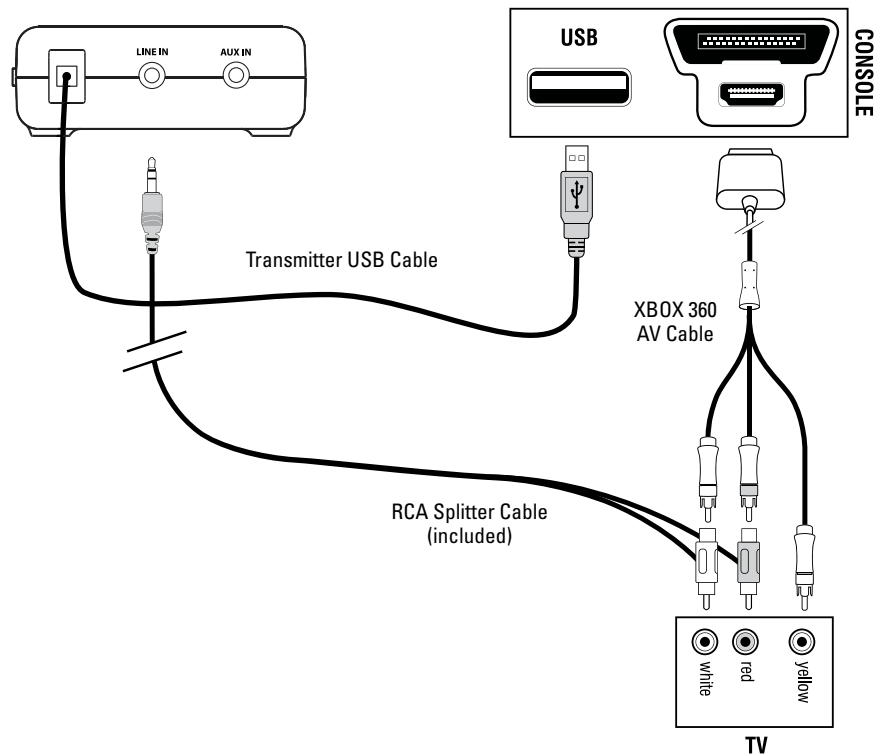

XBOX 360 Chat Setup

1. Insert the right angle plug into the headphone jack on the XBOX 360 controller.
2. Insert straight plug into the controller jack on the left ear cup of the headset.

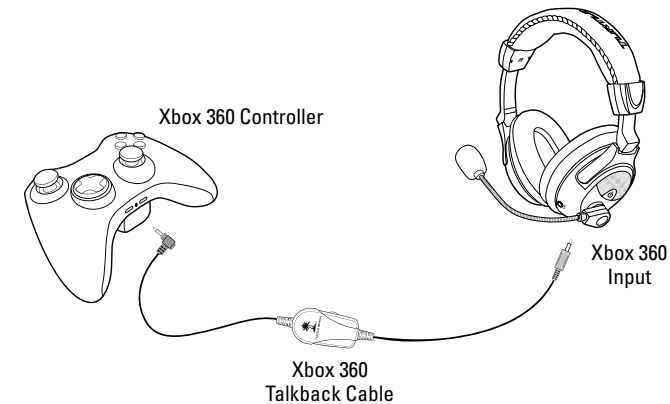
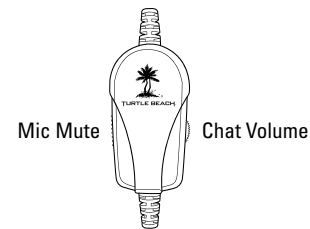

Configure XBOX 360 Settings

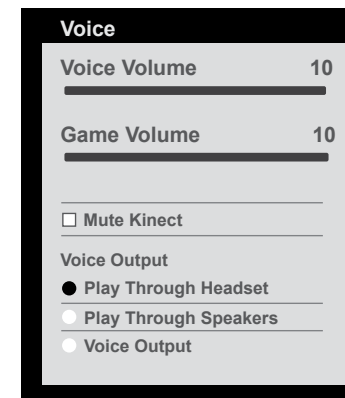

1. Press the XBOX 360 Guide Button, select "Settings > Preferences > Voice"
2. Voice Volume = **10**
3. Game Volume = **10**
4. Voice Output = **Play Through Headset**

Connecting a Digital Music Player

The X32 features an auxiliary input for connecting digital music players or other analog sources so you can listen to your own music along with the game audio. The Auxiliary Input volume can be adjusted directly from the digital music player.

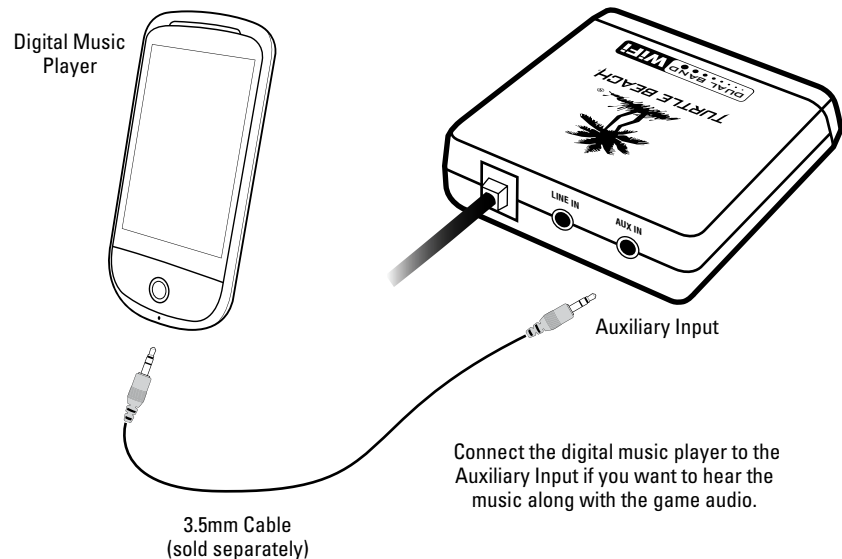

Connecting a DSS or DSS2

The X32 can be upgraded to Dolby® Digital surround sound by adding the Ear Force DSS or DSS2 surround sound processors (sold separately). Visit www.turtlebeach.com/DSS2 to learn how you can upgrade your X32 headset with surround sound.



Setup

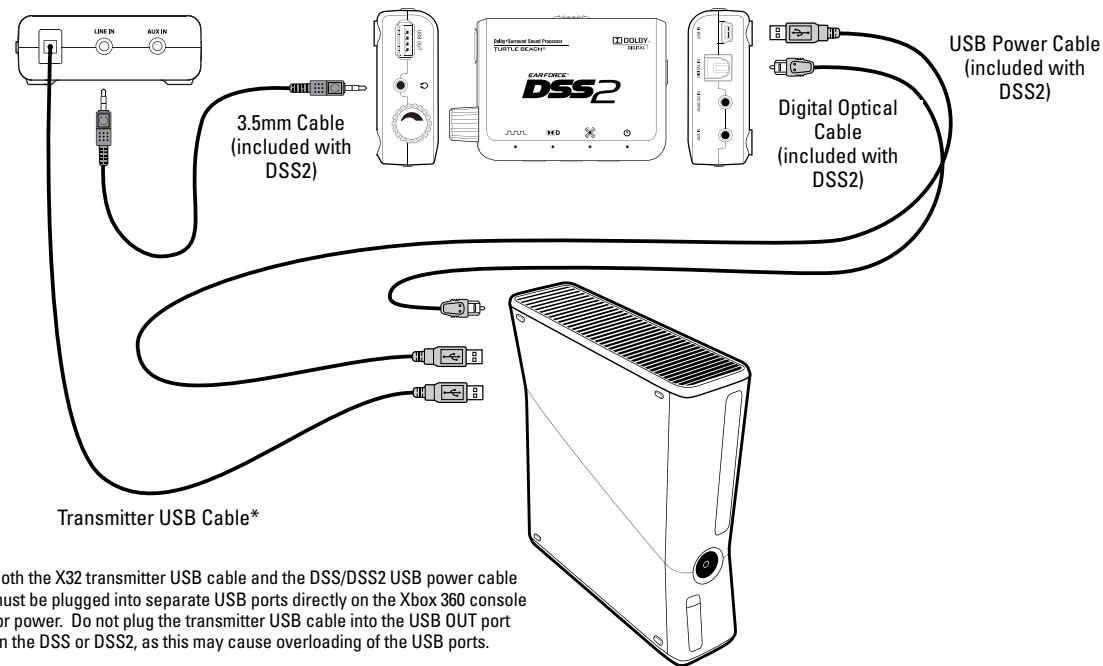

*Both the X32 transmitter USB cable and the DSS/DSS2 USB power cable must be plugged into separate USB ports directly on the Xbox 360 console for power. Do not plug the transmitter USB cable into the USB OUT port on the DSS or DSS2, as this may cause overloading of the USB ports.

Tone (EQ) Presets

The X32 features multiple Equalizer presets to enhance your gaming audio experience. Press the TONE button on the X32 headset to cycle through the EQ presets as illustrated below:

Equalizer (EQ) Presets:

1. Flat
2. Bass Boost
3. Treble Boost
4. Bass and Treble Boost

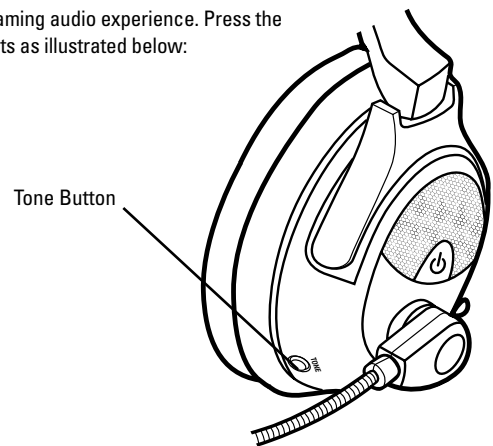

Effects (Sound Field Expander) Presets

The Sound Field Expander improves your ability to hear sounds coming from a distance by boosting sounds on the left and right sides and lowering sounds in the center. Press the EFFECTS button to cycle through the three settings as illustrated below:

Tone (Sound Field Expander) Presets:

1. Normal
2. Narrow
3. Wide

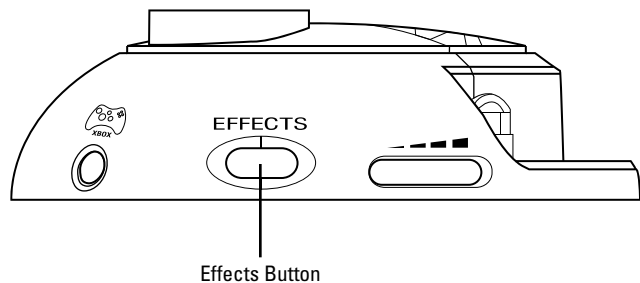

Chat Boost™

Chat Boost is a dynamic talkback expander built into the X32 headset that automatically increases chat volume during loud moments in your game, so you can always hear your teammates or other players, regardless of the game volume.

Typically, if you turn up a headset's game volume, the incoming chat level from other players could become difficult to hear over the game sound. However, with Chat Boost, as the game audio increases, the chat volume also increases. When the game volume quiets down again, Chat Boost automatically returns the chat level to your original volume setting.

To properly set the Chat Boost function:

1. Turn down the volume control on the headset so there's no game audio.
2. Adjust the volume control on the talkback cable so you can hear the chat voices at a comfortable level.
3. Turn up the headset game volume and the chat volume will increase whenever the game gets louder, just as if the talkback volume control is being automatically turned up along with the game level. Note that if the volume on the talkback cable is set too loud, Chat Boost might increase the volume so much that the voices will distort. If that happens, turn down the talkback volume on the talkback cable.

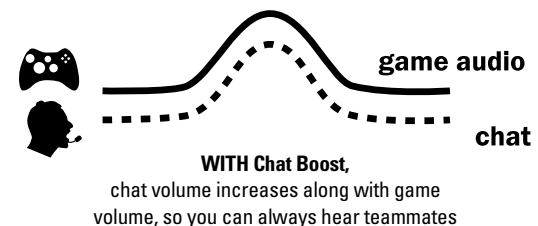
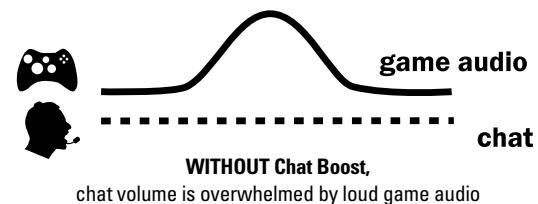

NOTE: If the volume on the talkback cable is set too loud, Chat Boost might increase the volume so much that the voices will distort. If that happens, turn down the talkback volume on the talkback cable.

X32 Headset Technical Specifications

- 50mm diameter speakers with neodymium magnets
- Game audio frequency response: 20Hz - 20kHz, >120dB SPL @ 1kHz
- Condenser microphone frequency response: 50Hz - 15kHz
- Game audio Dual Band WiFi Digital 2.4GHz/5.8GHz RF wireless reception
- Headphone amplifier: Stereo 27mW/ch, THD <1%
- Operates on (2) AAA batteries or (2) AAA rechargeable NiMH batteries
- Automatic shut down after approx 5 minutes of carrier loss or audio silence to conserve battery power
- Battery booster circuit extends battery life for up to 15 hours

X32 Transmitter Technical Specifications

- Dual Band WiFi Digital 2.4GHz/5.8GHz RF wireless transmission with up to 30 foot range
- Frequency response: 20Hz - 20kHz
- Stereo 3.5mm line input jack
- Stereo 3.5mm aux input jack
- Maximum analog input level: 2Vpp (700mV rms)
- USB Power – (5V DC @ 180mA max)

Troubleshooting

No sound

- Check that the headset volume control is turned up.
- Check that the transmitter USB power and Line In cables are properly connected.
- Check that the headset is powered on. The LED on the left ear cup should be flashing.
- Check if the LED on the front of the transmitter is on solid. If the LED is slowly pulsing, it indicates that the transmitter isn't communicating with the headset. If the headset is on solid and the transmitter LED is slowly pulsing, then the headset and transmitter need to be "paired" as described in the section "Pairing the Headset and Transmitter".

Audio Drops, Popping or Clicking Sounds

Audio dropouts, popping or clicking sounds on the headset are caused by poor reception. This can occur when:

- The headset and transmitter are out of range. For best performance, stand within 20 feet from the transmitter.
- There's a wall or other large object between the headset and transmitter.
- The transmitter is in a bad location that is interfering with the antenna.
- A wireless base station or wireless router is causing a lot of RF activity that's blocking the RF signal from the transmitter.

Voice Chat Drops

- Most in-game voice chat drops are simply caused by network performance or "lag". Usually they subside after a few moments so please be patient. In extreme cases, you may have to leave a game and return to reset the chat function.
- If you use a wireless internet connection, low signal strength from your modem/router can make the voice chat malfunction. A wired connection from your modem/router to your console is recommended for best results.

Safety Notice

To avoid potential damage to the device, always disconnect all cables before transporting it.

WARNING: Permanent hearing damage can occur if a headset is used at high volumes for extended periods of time, so it is important to keep the volume at a safe level. Over time, your ears adapt to loud volume levels, so a level that may not cause initial discomfort can still damage your hearing. If you experience ringing in your ears after listening with the headset, it means the volume is set too loud.

The louder the volume is set, the less time it takes to affect your hearing. So, please take care to listen at moderate levels.

- Before placing a headset on your ears, turn the volume down completely, then slowly increase it to a comfortable level.
- Turn down the volume if you can't hear people speaking near you.
- Avoid turning up the volume to block out noisy surroundings.

EC Declaration of Conformity

Manufacturer: Voyetra Turtle Beach
Manufacturers Address: 150 Clearbrook Rd. Suite 162, Elmsford, NY 10523
Product Name: Ear Force X32
Type of Product: Wireless Headset
Model Number(s): TBS-2265-01
Year of Manufacture: 2011

We, Voyetra Turtle Beach, Inc. of Elmsford, New York, declare under our own responsibility that the above-referenced product complies with the following directives and standards:

Low Voltage Directive 2006/95/EC
EN 50332-2:2003
EN 60950-1:2006+A11:2009

Electromagnetic Compatibility Directive 1999/5/EC
ESTI EN 301 489-1 V1.8.1 (2008)
ESTI EN 301 489-3 V1.4.1 (2002)
ESTI EN 301 489-17 V2.1.1 (2009)

R&TTE Directive 1999/5/EC
ESTI EN 300 328 V1.7.1 (2006-10)
ESTI EN 300 440-1 V1.4.1 (2008-05)
ESTI EN 300 440-2 V1.2.1 (2008-05)

All test reports have been reviewed and approved with a Positive Opinion from the following Notified Bodies:

Bay Area Compliance Laboratories, Corp (Shenzhen)
6/F, the 3rd Phase of WanLi Industrial Building
ShiHua Road, FuTian Free Trade Zone, Shenzhen, Guangdong, China
Tel: +86-755-33320018, Fax: +86-755-33320008, Web: baclcorp.com

Shenzhen EBO Technology Co., Ltd.
No. 710 Yihua Building, Futian District, Shenzhen, China 518040
Tel: +86-755-29451282 Fax: 86-755-83709189 Web: ebotech.cn

The technical documentation required by this Directive is maintained at the corporate headquarters of Voyetra Turtle Beach, 150 Clearbrook Road. Suite 162, Elmsford, New York, 10562.

Authorized Person:



Printed Name: Frederick Romano
Title: Executive Vice President

Date: 11/17/11

FCC Declaration of Conformity

Product Name: Ear Force XP500
Model Number(s): TBS-2265-01
FCC Rules: FCC CFR Title 47 Part 15 Subpart B: 2009 CLASS B
FCC CFR Title 47 Part 15 Subpart C: 2008

Operating Environment: **GENERAL OFFICE AND HOME USE**

FCC COMPLIANT STATEMENT

This device complies with part 15 of the FCC rules. Operation is subjected to the following conditions:

- (1) This device may not cause harmful interference, and
- (2) This device must accept any interference received including interference that may cause undesired operation.

INFORMATION TO USER

This equipment has been tested and found to comply with the limits for a Class B digital device, pursuant to Part 15 of FCC rules. These limits are designed to provide reasonable protection against harmful interference in a residential installation. This equipment generates, uses and can radiate radio frequency energy and, if not installed and used in accordance with the instructions, may cause harmful interference to radio communications. However, there is no guarantee that interference will not occur in a particular installation. If this equipment does cause harmful interference to radio or television reception, which can be determined by turning the equipment off and on, the user is encouraged to try to correct the interference by one or more of the following measures:

- 1) Reorient or relocate the receiving antenna.
- 2) Increase the separation between the equipment and receiver.
- 3) Connect the equipment into an outlet on a circuit different from that to which the receiver is connected.
- 4) Consult the dealer or an experienced radio/TV technician for help.

The user's manual or instruction manual for an intention or unintentional radiator shall caution the user that the changes or modifications not expressly approved by the party responsible for compliance could void the user's authority to operate the equipment.

WARNING: Changes or modifications made to this equipment not expressly approved by VOYETRA TURTLE BEACH, INC. may void user's authority to operate this equipment.

Limited Warranty for Turtle Beach Products

Voyetra Turtle Beach, Inc. ("VTB") warrants to the original end-user purchaser ("Purchaser") that the retail Turtle Beach hardware product herein ("Product") will be free of defects in materials and workmanship for a period of one year from the date of purchase by the Purchaser ("Warranty Period"). Any Extended Warranty or Service Plans purchased through a Retail store are not honored by VTB. The Warranty refers to the repair/replacement of a defective product during this period and not a refund.

This limited warranty extends only to the Purchaser and is not transferable or assignable to any subsequent purchaser. This limited warranty is applicable only in the country or territory where the Product was purchased from an authorized VTB retailer and does not apply to a Product that has been purchased as used or refurbished (except refurbished by VTB) or was included as part of a non-VTB product.

WARRANTY SERVICE

In the USA and CANADA Warranty Service is provided by our TURTLE BEACH OFFICES and in all other Countries it is provided by our local International Distributors.

VTB does not warrant uninterrupted or error-free operation of the Product and is under no obligation to support the Product for all computer operating systems or future versions of such operating systems.

If a defect should occur during the Warranty Period, Purchaser must contact VTB to obtain a Return Merchandise Authorization ("RMA") number. Purchaser will be responsible for shipping costs incurred in returning the defective Product to an authorized VTB service center, or to the repair facility located at VTB's corporate headquarters. A copy of the dated proof of purchase and a description of the problem must be included with the defective Product. VTB will not be responsible for other products or accessories included with the defective Product sent to VTB. The RMA number must be clearly indicated on the outside of the package. Packages without an RMA number will be refused by VTB or its representatives and returned to sender at the sender's expense.

In the event of a defect, Purchaser's sole and exclusive remedy, and VTB's sole liability, is expressly limited to the correction of the defect by adjustment, repair, or replacement of the Product at VTB's sole option and expense. VTB owns all Products it has replaced and all parts removed from repaired Products. VTB uses new and reconditioned parts made by various manufacturers in performing warranty repairs and building replacement products. If VTB repairs or replaces a product, the original Warranty Period is not extended, however, VTB warrants that repaired or replacement parts will be free from defects in material and workmanship for a period of thirty (30) days from the date of repair or replacement, or for the remainder of the Warranty Period, whichever is greater.

This warranty does not apply to any Product that has had its serial number altered, removed or defaced, or any Product damage caused by shipping, improper storage, accident, problems with electrical power, abuse, misuse, neglect, ordinary wear, acts of God (e.g. flood), failure to follow directions, improper maintenance, use not in accordance with product instructions, unauthorized modification or service of the Product or damage resulting from the use of the Product with hardware, software or other products not provided by or specifically recommended by VTB.

THIS LIMITED WARRANTY IS PURCHASER'S SOLE AND EXCLUSIVE REMEDY AND IS IN LIEU OF ALL OTHER WARRANTIES, EXPRESS OR IMPLIED. TO THE EXTENT PERMITTED BY APPLICABLE LAW, VTB HEREBY DISCLAIMS THE APPLICABILITY OF ANY IMPLIED WARRANTY OF MERCHANTABILITY, FITNESS FOR A PARTICULAR PURPOSE OR USE FOR THE PRODUCT. IF SUCH A DISCLAIMER IS PROHIBITED BY APPLICABLE LAW, THE IMPLIED WARRANTY IS LIMITED TO THE DURATION OF THE FOREGOING LIMITED WRITTEN WARRANTY.

IN NO EVENT SHALL VTB BE LIABLE FOR ANY INDIRECT, INCIDENTAL, SPECIAL, PUNITIVE OR CONSEQUENTIAL DAMAGES, OR DAMAGES, INCLUDING BUT NOT LIMITED TO ANY LOST PROFITS, DATA, OR LOSS OF USE, ANY THIRD PARTY CLAIMS, AND ANY INJURY TO PROPERTY OR BODILY INJURY (INCLUDING DEATH) TO ANY PERSON, ARISING FROM OR RELATING TO THE USE OF THIS PRODUCT OR ARISING FROM BREACH OF THE WARRANTY, BREACH OF CONTRACT, NEGLIGENCE, TORT, OR STRICT LIABILITY, EVEN IF VTB HAS BEEN ADVISED OF THE POSSIBILITY OF SUCH DAMAGES.

This warranty supersedes all prior agreements or understandings, oral or written, relating to the Product, and no representation, promise or condition not contained herein will modify these terms. Some states do not allow the exclusion or limitation of incidental or consequential damages, so the above exclusion or limitation may not apply to you. This warranty gives you specific legal rights. You may also have other rights, which vary from state to state. Any action or lawsuit for breach of warranty must be commenced within eighteen (18) months following the purchase of the Product.

EXCLUSIONS FROM LIMITED WARRANTY:

This Limited Warranty shall not apply and VTB has no liability under this Limited Warranty if the Turtle Beach Product:

- is used for commercial purposes such as "LAN Centers" (including rental or lease);
- is modified or tampered with;
- is damaged by Acts of God, power surge, misuse, abuse, negligence, accident, wear and tear, mishandling, misapplication, or other causes unrelated to defective materials or workmanship;
- serial number is defaced, altered or removed;
- is not used in accordance with the documentation and use instructions; or
- is repaired, modified or altered by other than authorized repair centers.
- product is no longer available because it was discarded.

Federal Communications Commission Interference Statement

This equipment has been tested and found to comply with the limits for a Class B digital device, pursuant to part 15 of the FCC Rules. These limits are designed to provide reasonable protection against harmful interference in a residential installation. This equipment generates, uses and can radiate radio frequency energy and, if not installed and used in accordance with the instructions, may cause harmful interference to radio communications. However, there is no guarantee that interference will not occur in a particular installation. If this equipment does cause harmful interference to radio or television reception, which can be determined by turning the equipment off and on, the user is encouraged to try to correct the interference by one or more of the following measures:

- Reorient or relocate the receiving antenna.
- Increase the separation between the equipment and receiver.
- Connect the equipment into an outlet on a circuit different from that to which the receiver is connected.
- Consult the dealer or an experienced radio/ TV technician for help.

FCC Caution:

Any changes or modifications not expressly approved by the grantee of this device could void the user's authority to operate the equipment.

RF Exposure Warning:

Headset:

The equipment complies with FCC RF exposure limits set forth for an uncontrolled environment. The equipment must not be co-located or operating in conjunction with any other antenna or transmitter.

Transmitter Box:

This equipment must be installed and operated in accordance with provided instructions and the antenna(s) used for this transmitter must be installed to provide a separation distance of at least 20 cm from all persons and must not be co-located or operating in conjunction with any other antenna or transmitter. End-users and installers must be provided with antenna installation instructions and transmitter operating conditions for satisfying RF exposure compliance.

CANADA, INDUSTRY CANADA (IC) NOTICES

This Class B digital apparatus complies with Canadian ICES-003 and RSS-210. Operation is subject to the following two conditions: (1) this device may not cause interference, and (2) this device must accept any interference, including interference that may cause undesired operation of the device.

Radio Frequency (RF) Exposure Information:

Headset:

The radiated output power of the Wireless Device is below the Industry Canada (IC) radio frequency exposure limits. The Wireless Device should be used in such a manner such that the potential for human contact during normal operation is minimized. This device has also been evaluated and shown compliant with the IC RF Exposure limits under portable exposure conditions. (antennas are less than 20 cm of a person's body).

Transmitter:

The radiated output power of the Wireless Device is below the Industry Canada (IC) radio frequency exposure limits. The Wireless Device should be used in such a manner such that

the potential for human contact during normal operation is minimized. This device has also been evaluated and shown compliant with the IC RF Exposure limits under mobile exposure conditions. (antennas are greater than 20cm from a person's body).

This device has been certified for use in Canada. Status of the listing in the Industry Canada's

REL (Radio Equipment List) can be found at the following web address: <http://www.ic.gc.ca/app/sit/reltel/srch/nwRdSrch.do?lang=eng>
Additional Canadian information on RF exposure also can be found at the following web address: <http://www.ic.gc.ca/eic/site/smt-gst.nsf/eng/sf08792.html>

Canada, avis d'Industry Canada (IC)

Cet appareil numérique de classe B est conforme aux normes canadiennes ICES-003 et RSS-210. Son fonctionnement est soumis aux deux conditions suivantes : (1) cet appareil ne doit pas causer d'interférence et (2) cet appareil doit accepter toute interférence, notamment les interférences qui peuvent affecter son fonctionnement.

Informations concernant l'exposition aux fréquences radio (RF)

Headset:

La puissance de sortie émise par l'appareil de sans fil Dell est inférieure à la limite d'exposition aux fréquences radio d'Industry Canada (IC). Utilisez l'appareil de sans fil Dell de façon à minimiser les contacts humains lors du fonctionnement normal. Ce périphérique a également été évalué et démontré conforme aux limites d'exposition aux RF d'IC dans des conditions d'exposition à des appareils portables (les antennes sont moins de 20 cm du corps d'une personne).

Transmitter:

La puissance de sortie émise par l'appareil de sans fil Dell est inférieure à la limite d'exposition aux fréquences radio d'Industry Canada (IC). Utilisez l'appareil de sans fil Dell de façon à minimiser les contacts humains lors du fonctionnement normal. Ce périphérique a également été évalué et démontré conforme aux limites d'exposition aux RF d'IC dans des conditions d'exposition à des appareils mobiles (les antennes se situent à moins de 20 cm du corps d'une personne).

Ce périphérique est homologué pour l'utilisation au Canada. Pour consulter l'entrée correspondant à l'appareil dans la liste d'équipement radio (REL - Radio Equipment List) d'Industry Canada rendez-vous sur: <http://www.ic.gc.ca/app/sit/reltel/srch/nwRdSrch.do?lang=eng>
Pour des informations supplémentaires concernant l'exposition aux RF au Canada rendez-vous sur: <http://www.ic.gc.ca/eic/site/smt-gst.nsf/eng/sf08792.html>

This product is CE marked according to the provisions of the Low Voltage Directive (2006/95/EC), R&TTE Directive (1999/5/EC) and EMC Directive (1999/5/EC).
Frequency Range: 2.404-2.476GHz / 5.160-5.340GHz

• Grantee Code/Reg Number: XGB/GC229855 • Voyetra Turtle Beach, Inc.



IC: 3879A-2265

IC: 3879A-2266



For more products, accessories and general product information, please visit
TurtleBeach.com

For warranty information and product support, please visit
TurtleBeach.com/support

DESIGNED AND ENGINEERED BY TURTLE BEACH IN NEW YORK, USA

Copyright © 2012 Voyetra Turtle Beach, Inc. (VTB, Inc.) All rights reserved. No part of this guide may be reproduced without permission. Turtle Beach, the Turtle Beach Logo, Voyetra, Ear Force, Chat Boost, Engineered For Gaming and the Dual Band logo are either trademarks or registered trademarks of VTB, Inc. XBOX, XBOX 360 and XBOX LIVE are registered trademarks of Microsoft Corporation. Dolby and the double-D symbol are trademarks of Dolby Laboratories. All other trademarks are properties of their respective companies and are hereby acknowledged. Assembled in China. **PATENTS PENDING**



ENGINEERED FOR GAMING™

Join The Conversation



TURTLEBEACH.COM