



**Wireless Gaming Headphones with XBOX® Live Chat
and Dolby® 5.1 Channel Surround Sound**

Operating Instructions



For more products, accessories and our product support knowledge base, please visit

TurtleBeach.com

For warranty information, please visit <http://support.turtlebeach.com>

System Requirements

- XBOX 360 game console with one of the following cables to support digital output:
 - ◆ Xbox 360 Component HD AV cable
 - ◆ VGA HD AV cable
 - ◆ S-Video AV cable
 - ◆ Advanced SCART AV cable
- The X4 XBOX controller puck is not compatible with XBOX 360 Messenger Kit (a/k/a "Chatpad")
- XBOX Live requires a subscription.
- Power adapter requires connection to AC power.

Package Contents

- X4 wireless headphones
- Removable boom microphone
- Foam cover for microphone
- X4 infrared transmitter
- X4 DC power adapter
- Digital Optical cable
- (2) AAA batteries
- Xbox controller cable ("puck")
- This Quick Start Guide

This equipment has been tested and found to comply with the limits for a Class B digital device, pursuant to Part 15 of FCC rules. These limits are designed to provide reasonable protection against harmful interference in a residential installation. This equipment generates, uses, and can radiate radio frequency energy and, if not installed and used in accordance with the instructions, may cause harmful interference to radio communications. However, there is no guarantee that interference will not occur in a particular installation. If this equipment does cause harmful interference to radio or television reception, which can be determined by turning the equipment off and on, the user is encouraged to try to correct the interference by one or more of the following measures: (1.) Reorient or relocate the receiving antenna. (2.) Increase the separation between the equipment and receiver. (3.) Connect the equipment into an outlet on a circuit different from that to which the receiver is connected. (4.) Consult the dealer or an experienced radio TV technician for help.



Copyright © 2008 Voyetra Turtle Beach, Inc. (VTB, Inc.) All Rights Reserved. No part of this document may be reproduced without permission. The Turtle Beach Logo, Ear Force, Play Like a Pro, All Your Ears Are Belong to Us and Turtle Beach are registered trademarks of VTB, Inc. Chat Boost and X4 are trademarks of VTB, Inc. Xbox and XBOX Live are registered trademarks of Microsoft Corporation. Dolby, Pro Logic, and the double-D symbol are registered trademarks of Dolby Laboratories. All other Trademarks are properties of their respective owners and are hereby acknowledged. Product Features, visual design, prices, package contents and specifications are subject to change without notice. Manufactured under license from Dolby Laboratories. V1 P/N TBS-2067-01

Main Features

The Ear Force X4 Dolby surround sound gaming headphone system uses an infrared signal to transmit wireless game audio from the XBOX 360 to the X4 wireless headphones. The X4 transmitter uses Dolby Headphone technology to produce a more realistic game experience by recreating the sound of a 5.1 channel speaker system with the X4 stereo headphones. The X4 incorporates the following features designed specifically to enhance Xbox 360 gaming:

- Dolby Digital, Dolby Pro Logic II and Dolby Headphone processing technology.
- Digital and analog inputs for listening to the XBOX and other audio sources.
- High powered IR beam covers a wide reception range for freedom of movement during game play.
- Large, soft ear cushions and lightweight design for optimum comfort during long gaming sessions.
- Chat Boost automatically adjusts Xbox Live chat levels during loud game play.
- Microphone monitor lets you hear what you're saying.
- Bass boost enhances deep game sounds.
- Independent volume controls for balancing game and chat levels.
- Automatic power-off function turns off the headphones after a period of no sound to conserve battery power.

Technical Specifications

X4 Transmitter

- IR FM Modulated carrier transmission (2.3/2.8MHz).
- Automatic shut down of carrier transmission after approx. 2 minutes of silence
- IR transmission range at zero degrees > 30 feet.
- Automatic Gain Control (AGC) on FM transmitter limits carrier over-modulation.
- Frequency response: 20Hz - 20kHz
- Optical TOSLINK digital audio input compatible with 48kHz digital audio stream
- Optical TOSLINK digital audio output pass-through of digital input stream.
- 150MIPS Digital Signal Processor for Dolby processing
- Maximum analog input level with volume control on maximum setting: 2Vpp (700mV rms). Input sensitivity may be adjusted to accept higher level signals by lowering the volume control.
- Weight: 8.4 Oz (240g)
- Power adapter: 9VDC @360mA (100VAC - 240VAC)

X4 Headphones

- 50mm diameter speakers with neodymium magnets
- IR FM modulated carrier reception (2.3/2.8MHz)
- Speaker Frequency Response: 20Hz - 20kHz , >120dB SPL @ 1kHz
- Condenser Microphone Frequency Response: 50Hz - 15kHz
- Headphone Amplifier: Stereo DC-coupled, 35mW/ch, THD <1%, Frequency Response: DC - 30kHz
- Bass Boost: +9dB @20Hz - 150Hz
- Chat Boost Talkback Expander: +10dB gain boost at maximum game volume
- Audio mutes automatically when carrier signal is lost
- Quad IR sensors for full 360 degree reception range
- Operates on dual AAA batteries
- Automatic battery power shut down after approx 2 minutes of carrier loss
- Battery life: Greater than 20 hours of continuous use with alkaline cells
- Weight: 9.5 Oz (270g)

X4 Transmitter

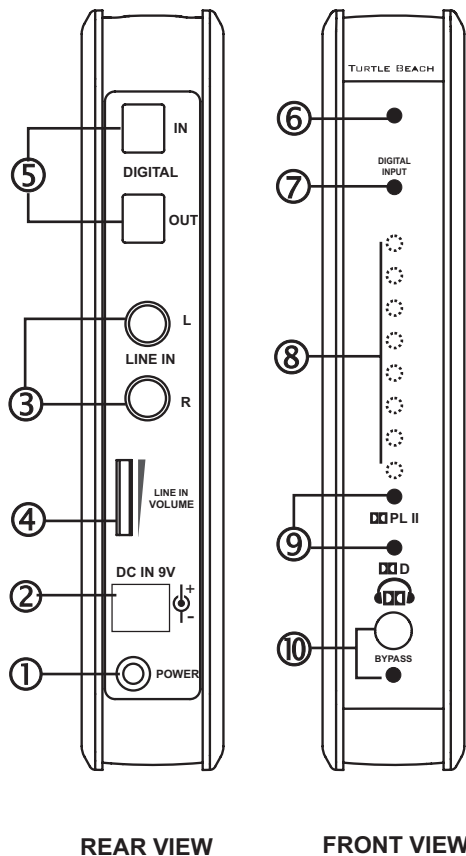

REAR VIEW

FRONT VIEW

- ① **Power Switch:** Push to turn on the transmitter power. When the unit is powered on, the front panel power light (6) will be on.

NOTE: Switching the power button on and off repeatedly may cause the transmitter to not power up correctly. If this happens, turn off the transmitter power, wait a few seconds, then turn it on again so that it may reset properly.

- ② **Power Socket:** Insert the included X4 power adapter into this socket.

CAUTION: Use only the supplied power adapter. Failure to use the correct adapter can result in fire, damage to the unit or other hazards.

- ③ **Line In (stereo analog inputs):** Use these inputs to connect analog audio sources, such as a TV, MP3 Player, etc. If the Bypass (10) is turned off, the analog stereo signal will be processed by the Dolby Pro Logic II decoder, producing an expanded stereo effect.

- ④ **Volume control:** Sets the sensitivity of the analog inputs to accept a wide range of input levels. **This control has no effect on the digital input signal level.** Typically, this should be set to maximum and the headphone volume should be used to adjust the listening level. If the sound distorts, turn down the transmitter volume control (4) to prevent overloading the analog inputs.

- ⑤ **Digital Input and Output:** Connect the X4 digital input (top) to the XBOX 360 digital output using the included fiber optic cable. The X4 digital input (top) is passed through to the X4 digital output (bottom) so you can simultaneously connect the X4 transmitter and your home theater system to hear the Xbox on the headphones and speakers at the same time. **When the Xbox digital signal is active, the X4 transmitter's analog inputs are disabled.**

- ⑥ **Power Indicator:** Lights when the unit is powered on.

- ⑦ **Digital Input Indicator:** Lights when a digital signal is detected on the digital input.

- ⑧ **IR Emitters:** The IR emitters are located in this area and should remain free of any obstructions that may block the IR light beam from reaching the headphones.

- ⑨ **Dolby Processing Indicators:** The **PL II** indicator will light whenever the digital or analog input is being processed by the Dolby Pro Logic II decoder. The **D** indicator will light whenever the digital input signal is being processed by the Dolby Digital 5.1 surround sound decoder. Both indicators will turn off when the Bypass is ON.

- ⑩ **Bypass Button and Indicator:** Pressing this button turns off the Dolby processing, allowing you to hear the unmodified input signal. The light will turn on to indicate that Bypass is active and Dolby Processing is disabled.

Transmitter Range

The transmitter communicates with the headphones via an infrared (IR) light beam, so it is important to maintain a direct line of sight between the transmitter and the headphones. Do not obstruct the front of the transmitter in the area containing the IR emitters, as described above. Because of the IR beam intensity, **standing too close to the transmitter will overload the headphone infrared receivers and shut off the headphone volume. For best reception, stand between 4' and 30' from the transmitter.**

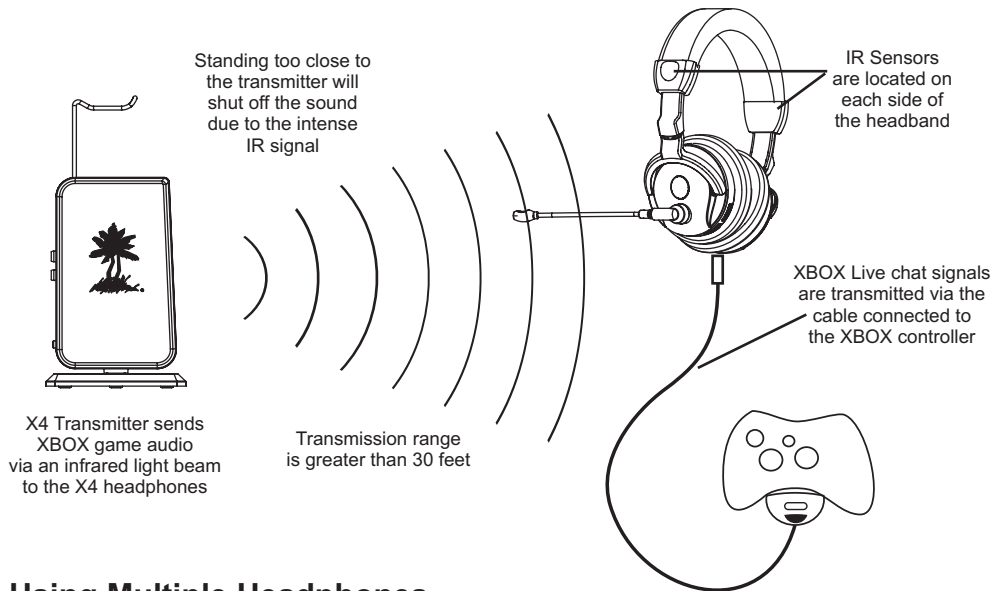

Using Multiple Headphones

By using additional X4 headphones (sold separately) a group of people can enjoy the same Xbox game, watch the same DVD movie, etc. For XBOX Live chat, each headset will need to be connected to its own XBOX controller.

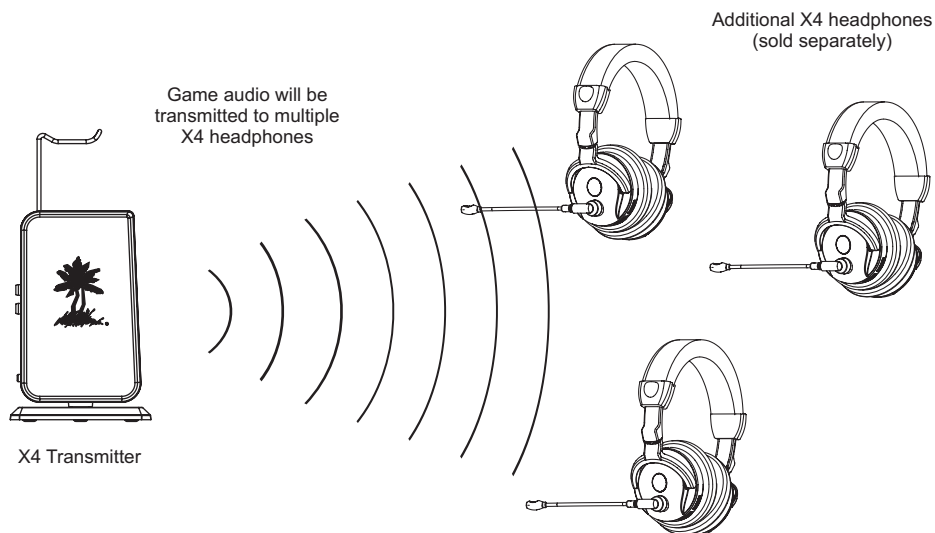

X4 Headphones

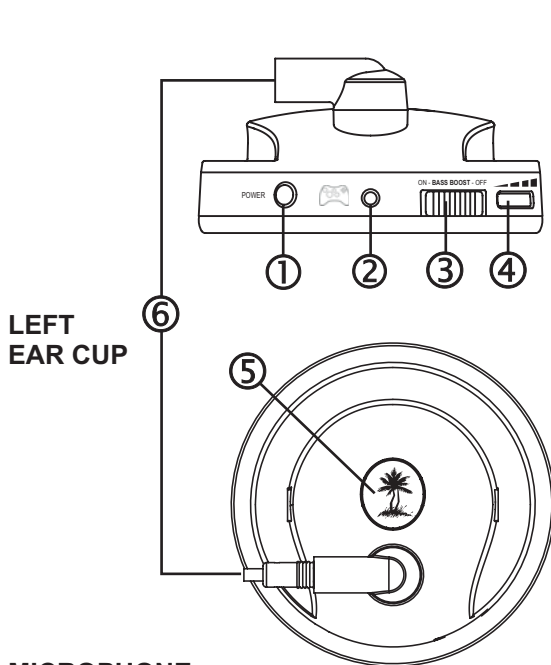

LEFT EAR CUP

MICROPHONE

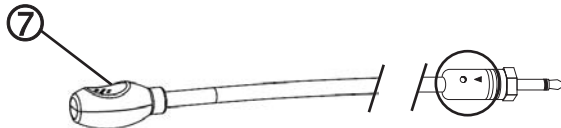

Remove the foam cover and insert the mic boom so the holes in the mic casing are facing your mouth. Then replace the foam cover.

Markers on the jack indicate the proper position when the foam cover is on the mic

RIGHT EAR CUP

Insert both AAA batteries with the positive side facing down

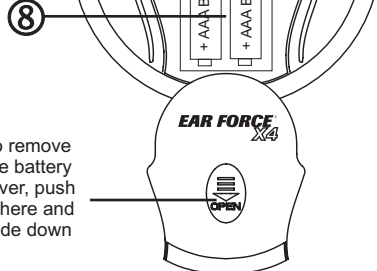

To remove the battery cover, push in here and slide down

- 1 **Power Switch:** Push to turn on the headphones. Push again to turn off. When power is on, the power light (5) flashes about once per second.

Automatic Power Shut-off Feature:

If there is no sound transmitted for more than a few minutes, or if the headphones are outside of the transmitter's range, the power light (5) will flash faster to indicate that the headphones are about to shut off. If the sound or transmitter signal do not return within approximately two minutes, the headphone power will shut off to conserve battery power.

- 2 **XBOX Controller Jack:** Insert the small connector at the end of the Xbox controller cable (see below) here.

- 3 **Bass Boost Switch:** Slide into the "ON" position to boost the bass frequencies in the game audio.

- 4 **Game Volume:** Turn to adjust the game sound level. The Xbox Live chat volume may be independently set by the volume control on the Xbox controller cable puck.

- 5 **Power Light:** Flashes about once per second when power is on. Flashes faster when power is about to be turned off automatically, as described above. Stops flashing and stays lit when the batteries are critically low and should be replaced.

- 6 **Microphone socket:** Insert the removable mic boom here. The socket is notched to prevent the boom from rotating after insertion.

- 7 **To properly position the mic,** remove the foam cover, insert the boom into the socket (6) so the holes on the mic casing (7) are facing your mouth. Then replace the foam cover. The boom jack also has a marker to indicate the proper mic position.

- 8 **Installing Batteries:** The headphones are powered by 2 AAA batteries located in the right ear cup. Push in and pull down on the lid to remove. Then insert both batteries with the positive sides facing down.

XBOX Controller Cable ("Puck")

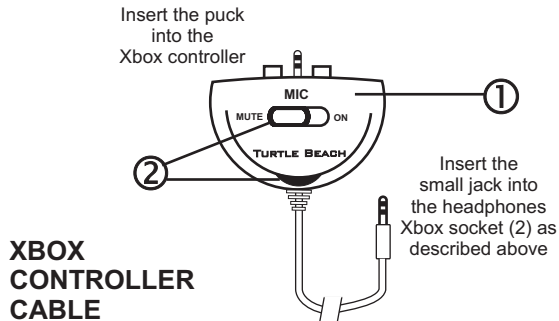

① **Puck:** To connect the Xbox Live chat signals, insert the puck into the Xbox controller and insert the small jack on the other end of the cable into the Xbox socket (2) on the headphones.

② **Chat volume and Mic Mute:** Use the mic mute switch to turn off the mic when you don't want to be heard. Use the volume control to adjust the chat level in the headphones.

Transmitter Input Modes and Dolby Processing

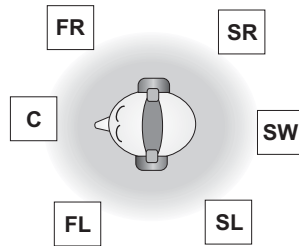

Sound field with Dolby Headphone surround sound processing

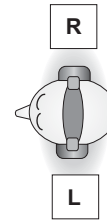

Stereo sound field

The X4 uses Dolby Pro Logic II, Dolby Digital, and Dolby Headphone surround processing technologies—the industry-standard formats for encoding multi-channel game audio. Dolby Headphone processing recreates 5.1 surround sound using the X4 stereo headphones so you can hear the sound all around you, as if you were listening to a 5.1 speaker system.

The X4 transmitter supports three types of digital source material and analog stereo. When the Bypass button is ON, Dolby Processing is defeated, so you can hear the unprocessed input signal in stereo, as it sounds from the source. Here's how the signal processing modes operate:

- When the digital input signal is active, the front panel digital light turns on and the analog inputs are turned off. So you don't have to disconnect cables to switch between analog and digital sound sources.
- If the Bypass LED is on, Dolby processing is defeated and the signal will be heard as stereo.
- If the digital input is a Dolby Digital 5.1 channel signal, the front panel DD light turns on and Dolby Headphone processes the 5.1 channels to create surround sound on the headphones.
- If the digital source is a Dolby Pro Logic II signal, both Dolby lights will turn on and Dolby Headphone creates PL II surround sound on the headphones.
- If the digital input is stereo, the DD PL II light turns on and the signal is processed by Dolby Headphone to create an expanded stereo sound on the headphones.
- If the digital input is not active (or is disconnected) the analog stereo signal will be active.
- If there is an analog stereo input and the Bypass LED is on, there will be no Dolby processing and the signal will be heard as stereo.
- If there is an analog stereo input and the Bypass LED is off, the front panel DD PL II light turns on and the analog stereo signal is processed by Dolby Pro Logic II and Dolby Headphone to create an expanded stereo sound on the headphones.

Setting up the XBOX 360 and Ear Force X4

STEP 1: Connect the XBOX to the X4 Transmitter

1. Connect the XBOX 360 Component HD AV cable or S-Video AV Cable to your Xbox as described in the Xbox user guide.

2. Connect the TOSLINK digital optical cable (included with your X4) from the digital output on the Xbox cable (1) to the digital input on the transmitter (2).

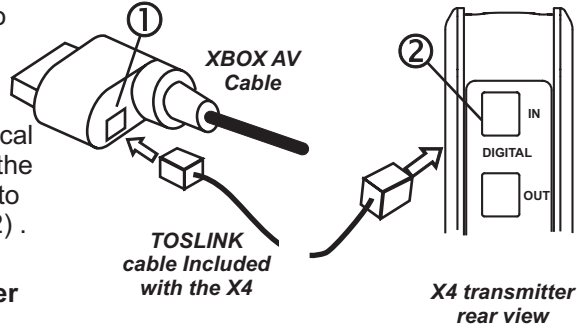

Step 2: Connect the power adapter

1. Connect the DC power adapter to the X4 power socket and plug the power adapter into an AC outlet.

2. Press the power switch (3) and check if the power LED indicator on the front panel is on.

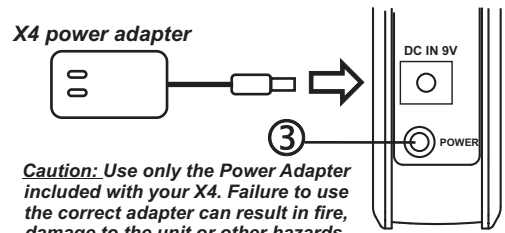

Caution: Use only the Power Adapter included with your X4. Failure to use the correct adapter can result in fire, damage to the unit or other hazards.

Step 3: Insert the X4 headphone batteries

1. Remove the battery cover (4) in the right ear cup by pushing in and down.

2. Insert the included AAA batteries with the positive side facing down.

3. Replace the battery cover.

4. Press the headphones power button (5) and check if the power LED is flashing. If not, check if the batteries are inserted correctly.

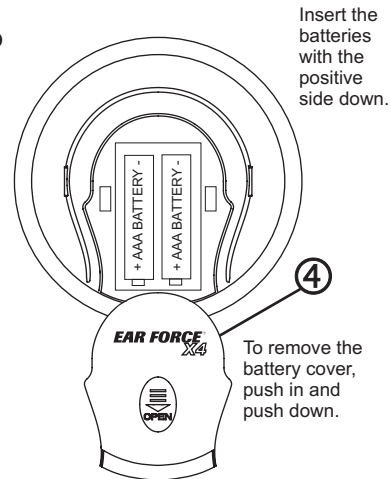

Step 4: Insert the mic boom

1. Insert the mic boom into the jack (6) so that the holes in the mic casing are facing your mouth.

2. Place the foam cover over the mic if desired.

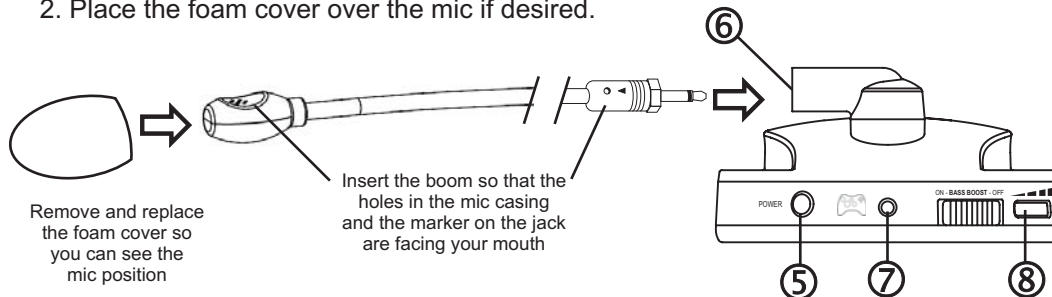

STEP 5: Connect the XBOX controller to the X4 headphones

1. Insert the small jack on the Xbox Controller cable (included with your X4) into the Xbox jack (labeled with the controller symbol) on the X4 headphones.

2. Insert the "puck" side of the talkback cable into the Xbox controller. Make sure it sits snugly against the controller body and is not loose.

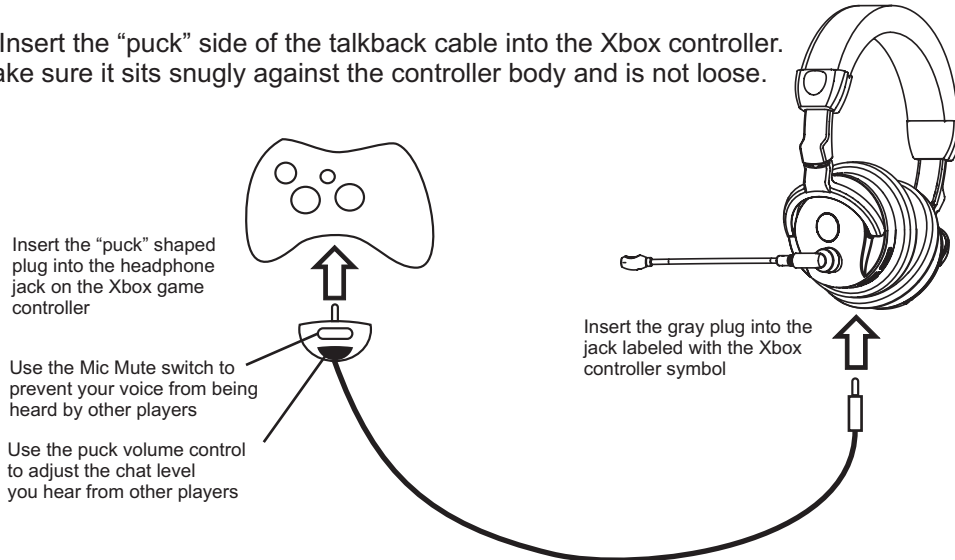

STEP 6: Configure the XBOX Live Chat audio settings

1. From the Xbox 360 Dashboard, press the Xbox **Guide** button (the X button in the center of your controller) to access your Xbox Live Settings.

2. Navigate to the **Personal Settings** selection, and press the **"A"** button on the controller. Select **Voice** from the menu and press the **"A"** button again.

3. On the Voice screen, select **"Play Through Headset"** for Voice Output selection and set the volume to 10. You can fine tune game audio and chat volumes using the X4 headphone and game controller volume controls.



STEP 7: Configure the XBOX audio settings

1. In the System section of the Xbox Dashboard, select **Console Settings**, then select **Audio**.

2. In the Audio Settings area, select **Dolby Digital 5.1** to activate the Dolby Digital output.

3. Start your game and turn up the headphone volume (8) to a comfortable level.

Connecting your Home Theater Speakers and TV

By configuring the X4 transmitter as illustrated below, you can listen to the Xbox or TV with the X4 headphones, and you can also hear the Xbox game on your home theater speakers without disconnecting the X4 transmitter.

The X4 transmitter's analog inputs connected to the TV will automatically shut off whenever the Xbox is active. When the Xbox is turned off, the analog inputs will automatically turn on so you can listen to TV shows with the X4 headphones without having to disconnect cables.

Connecting the X4 transmitter digital output to your home theater system will pass the Xbox game audio from the transmitter's digital input to the home theater AV receiver digital input, so you can hear the game on both the X4 headphones and your surround sound speakers at the same time. When you want to hear the game only on the X4 headphones, just turn down the volume or mute your AV receiver to shut off the speakers.

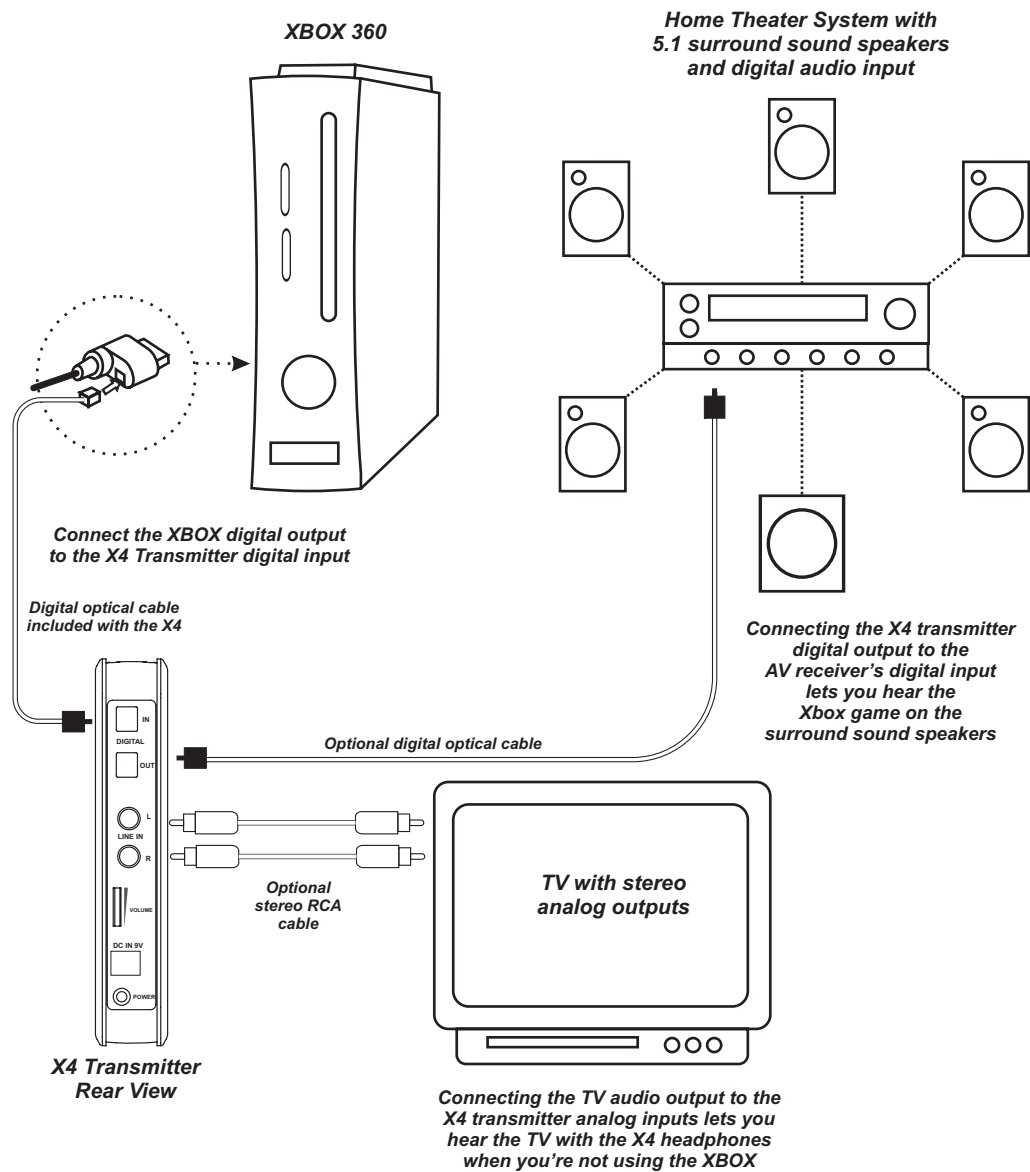

Using XBOX Live Chat with the X4 Headphones

Xbox Live is a subscription feature offered with the Xbox 360 that lets you communicate with other players via the Internet. The X4 microphone may be used to communicate with other players during XBOX Live multi-player gaming sessions. To use this feature, configure the Xbox Live feature as described below and connect the X4 headphones to the XBOX 360 controller as described in the previous section.

Mic Mute Switch: The mute switch on the "puck" plugged into the Xbox controller can be used to silence the X4 headphone mic when you don't want to be heard during Xbox Live sessions.

Chat Volume: The volume control on the "puck" lets you to adjust the chat volume of online players heard in your headphones. The X4's Chat Boost feature automatically increases the chat level as the game volume increases, as explained in the "Chat Boost" feature section below.

Adjusting the Microphone Position: For optimum clarity, adjust the microphone so that it is situated a few inches away from your mouth and the microphone's active area is facing your mouth. If you're not sure about the mic position, remove the foam mic cover, turn the holes in the mic housing towards your mouth and then replace the foam cover. Or, check the triangle marker on the boom jack, which is aligned with the mic holes and also should be facing your mouth.

Microphone Monitoring Feature: When the Xbox controller cable is inserted into the headphone's Xbox jack, the X4 mic monitor feature mixes a portion of the microphone signal into the headphone signal so you can hear your voice along with the online chatting and game audio.

Using the Ear Force X4 Chat Boost™ Feature

Chat Boost is a dynamic talkback expander built into the X4 headphones that automatically amplifies Xbox Live chat during loud moments in your game, so you can always hear your teammates, regardless of the game volume.

Typically, if you turn up the headphone game volume, the chat sound level could become difficult to hear over the game sound. However, with Chat Boost, as the game audio increases, the chat volume also increases and the chat voices will keep up with the game level so you can hear what the online players are saying. When the game volume quiets down again, Chat Boost automatically returns the chat level to the lower volume setting.

To properly set the Chat Boost function:

1. Turn down the volume control on the X4 headphones so there's no game audio.
2. Adjust the talkback volume control on the "puck" so you can hear the chat voices at a comfortable level.
3. Turn up the headphone game volume and the chat volume will increase whenever the game gets louder, just as if the talkback volume control is being automatically turned up along with the game level.

Note that if the talkback volume on the puck is set too loud, Chat Boost might increase the volume so much that the voices will distort. If that happens, turn down the talkback volume on the puck.

Helpful Tips

- ✓ Although the headphones will continue to operate on low battery power, the performance will degrade as the batteries begin to drop in voltage. **Change the batteries if...**
 1. You sense that the sound is dropping out more often than usual, or...
 2. The sound is distorting, regardless of the volume levels, or...
 3. The headphone power light is constantly on rather than flashing.
- ✓ If the sound is distorted when using the transmitter analog input, it may be that the audio source is overloading the X4 analog inputs. Try turning down the volume on the transmitter to reduce the input sensitivity, then turn up the headphone volume to a comfortable level.
Note that the transmitter volume control has no effect on the digital input.
- ✓ Standing too close to the transmitter can cause the IR signal to overload the headphones, which will mute the sound. For best performance, stand at a distance between 4' and 30' from the transmitter.
- ✓ The transmitter analog inputs will automatically shut off whenever the digital input is active. To hear the analog input signal, either disconnect the optical cable from the digital input on the transmitter, or shut off the device connected to the optical cable (e.g. Xbox) to disable the digital audio signal.
- ✓ Don't wear the headphones with the headband behind your head. The headband must be positioned on top of your head to optimize the surround sound effect.
- ✓ Don't cover the headphone IR sensors with your hands or hair.
- ✓ Don't use the system in areas exposed to direct sunlight or strong light or the IR signal may be reduced, causing the sound to be interrupted.
- ✓ Be sure to position the mic so that the jack indicator is facing your mouth. Or, remove the foam cover and check that the holes in the mic case are facing your mouth.
- ✓ Switching the power button on and off repeatedly may cause the transmitter to not power up correctly. If this happens, turn off the transmitter power, wait a few seconds, then turn it on again so that it may reset properly.

Using the X4 with Plasma TVs

Some plasma TVs generate infrared (IR) interference at the same frequencies used by the X4 transmitter. This IR interference can be picked up by the X4 headphones as a background "buzz" or "crackling" sound. This is not unique to the X4 headphones--*all analog IR headphones can exhibit this problem with plasma TVs.*

The plasma IR interference is most noticeable when there is no audio playing through the X4 transmitter, such as when the Xbox game menu is displayed or just before the game begins. Once the game sound begins, the X4 IR transmitter signal will overpower the plasma IR interference so the plasma generated noise in the headphones is eliminated.

Plasma IR interference decreases as you move further away from the screen. So it may be more noticeable if your TV is located in a small room and you're sitting closer to the TV screen. Also, if the X4 transmitter is placed too low, too high or too far to the side of the plasma screen, the X4 IR signal will be reduced because it is not in direct line-of-sight with the headphones. As a result, the plasma IR interference signal may be stronger than the X4 IR signal, resulting in plasma IR noise in the headphones.

To minimize or eliminate the plasma IR interference, it is important to maximize the X4 transmitter IR signal intensity and minimize the plasma IR interference signal. This may be accomplished by standing further away from the plasma TV screen and placing the transmitter either in direct line of sight with the headphones, or closer to the headphones.

X4 Volume Settings

The X4 system has three volume control settings that interact in the following manner:

Transmitter Volume Control for analog inputs (located on the back of the transmitter)

This controls only the volume of the stereo analog inputs and has no effect on the transmitter digital input volume. That means, if the Xbox is connected to the transmitter's digital input, the game volume will not be affected by this volume control. This volume control is only used when the analog inputs are being used (for example if you've connected your TV set to the transmitter) and in most cases it would be set to maximum. If you're using the transmitter analog inputs and hear distortion in the headphones, it could be caused by the input signal overloading the X4 transmitter. If that happens, turn down the transmitter volume control to reduce the analog input level until the distortion is corrected.

Headphone Game Volume Control (located on the headphones)

This volume control sets the volume of the game sound transmitted to the headphones. It has no effect on the Xbox Live chat volume, which is set independently as described below. If you're listening to an analog signal connected to the X4 transmitter (for example, if you've connected your TV to the transmitter), set the transmitter analog volume control as loud as possible for distortion-free sound and adjust the headphone volume to a comfortable level.

XBOX Live Chat Volume Control (located on the Xbox controller puck)

This controls the chat level heard in the headphones during an Xbox Live gaming session. Adjust the chat level with this control and adjust the game sound level with the volume control on the headphones. The volume control on the headphones has no effect on the chat volume level, so even if you turn the game volume control all the way down, you'll still hear the chat signal if the puck volume control is turned up.

Safety Notice

Be careful when turning up the headphones volume control. Before placing the headphones over your ears, set the volume control to minimum, then slowly increase until you reach a comfortable level.

Use only the supplied power adapter. Failure to use the correct power adapter can result in fire and permanent damage to the transmitter unit.

Do not over-drive the headphones. Like any speakers, playing the sound too loud on the headphones may cause damage to both the headphones and your ears. Please take care to listen at moderate levels.

To avoid potential damage while transporting the headphones, always disconnect the "puck" from the XBOX controller.

WARNING: Long term exposure to loud music or other sounds in headphones may cause hearing damage. Avoid extreme volume levels when using headphones, especially for extended periods. Over time, your ears adapt to the volume level, so a level that may not cause initial discomfort might still damage your hearing.

To avoid risk of electrical shock, do not remove the transmitter cover. There are no user-serviceable parts inside. Refer servicing to qualified service personnel.